

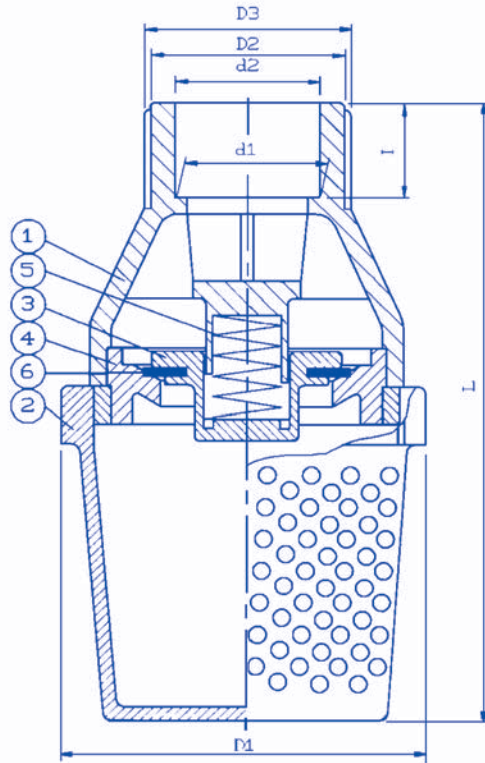

"QUALITY BY DESIGN"

**IN LINE SPRING CHECK FOOT VALVE
ENGINEERING SPECIFICATIONS**



PARTS

ITEM	PART	PIECES	MATERIAL
1	BODY	1	PVC
2	FILTER	1	PVC
3	SPIGOT	1	PVC
4	CONNECTOR SEAT	1	PVC
5	SPRING	1	SUS 304
6	SEAL	1	EPDM

ANSI DIMENSIONS

SIZE	d1	d2	d3	D1	D2	D3	L	I
25mm (1")	33.27	33.65	28	83	45	48	147	22.22
32mm (1 1/4")	42.04	42.42	35	83	52	55	170	23.82
40mm (1 1/2")	48.11	48.56	39	110	60	63	170	26.77
50mm (2")	60.17	60.63	52	124	73	76	198	29.36

25.4mm = 1" (inch)