

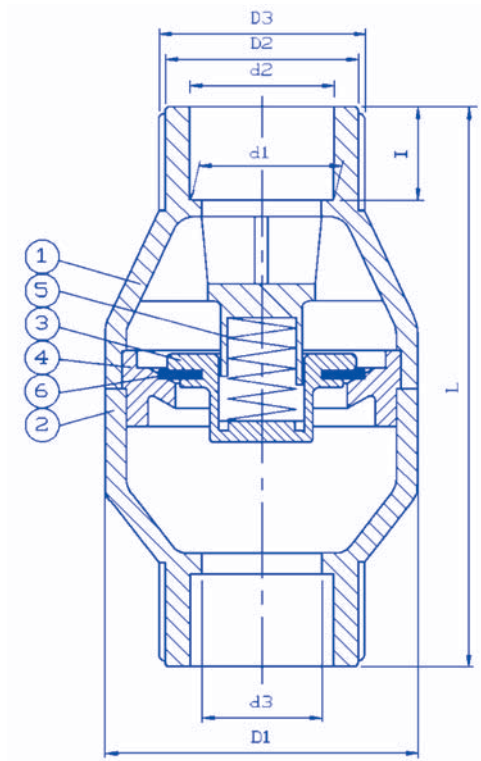

"QUALITY BY DESIGN"

IN LINE SPRING CHECK VALVE ENGINEERING SPECIFICATIONS



PARTS

ITEM	PART	PIECES	MATERIAL
1	UPPER BODY	1	PVC
2	LOWER BODY	1	PVC
3	SPIGOT	1	PVC
4	CONNECTOR SEAT	1	PVC
5	SPRING	2	SUS 304
6	SEAL	2	EPDM

ANSI DIMENSIONS

SIZE	d1	d2	d3	D1	D2	D3	L	I
20mm (3/4")	26.57	26.87	21	56	35	38	105	18.26
25mm (1")	33.27	33.65	28	73	45	48	133	22.22
32mm (1 1/4")	42.04	42.42	35	91	52	55	157	23.82
40mm (1 1/2")	48.11	48.56	39	91	60	63	157	26.77
50mm (2")	60.17	60.63	52	107	73	76	178	29.36

25.4mm = 1" (inch)

PVC VALVES
ENGINEERING SPECIFICATIONS
APPENDIX D